

MI-3625 Far-Field System - Dual-Axis / Network Analyzer

Key Features & Benefits

500 MHz to 6.0 GHz

- Rapid, accurate, continuous measurements using a network analyzer over the extended frequency range of 500 MHz to 6.0 GHz band provide increased flexibility and frequency control.
- Automated pattern measurements offer maximum flexibility and control with an advanced yet economical dual-axis DUT positioner.
- Network analyzer provides superior broadband measurements with high dynamic range and increased frequency resolution.
- Extensive analysis software is built-in to simplify pattern evaluation.
- Pattern plotting in polar or rectangular format for single or multiple patterns offers the ultimate in flexible data presentation.
- An Ethernet connection provides a means to easily download data for offline analysis.
- Dielectric elevation positioner produces low perturbations to the measurements.

Description:

The MI-3625 is a high-end, dual-axis far-field measurement system in the MI-3600 family designed for the Wireless market. Assembled to meet the needs of the most demanding test and measurement environments, the MI-3625 is a complete instrumentation system, consisting of a system controller computer and software, dual-axis positioner with combined azimuth and elevation angle control for rotating the Device-Under-Test (DUT), position controller, network analyzer, and broadband linearly polarized log periodic source antenna. The distinguishing elements of the MI-3625 are the vector network analyzer, which combines a broadband receiver with a broadband transmitter with coverage to 6.0 GHz, and dual-axis DUT positioner. The system provides superior ease of use that includes setup, test parameter provisioning, data acquisition, and data analysis. Using the workstation controller, an operator can select the transmit frequencies of operation and record the received signal from the broadband, highly accurate vector network analyzer. Various options include standard gain antennas for calibration, masts for source antenna and DUT positioner, longer signal and control cables and absorber.

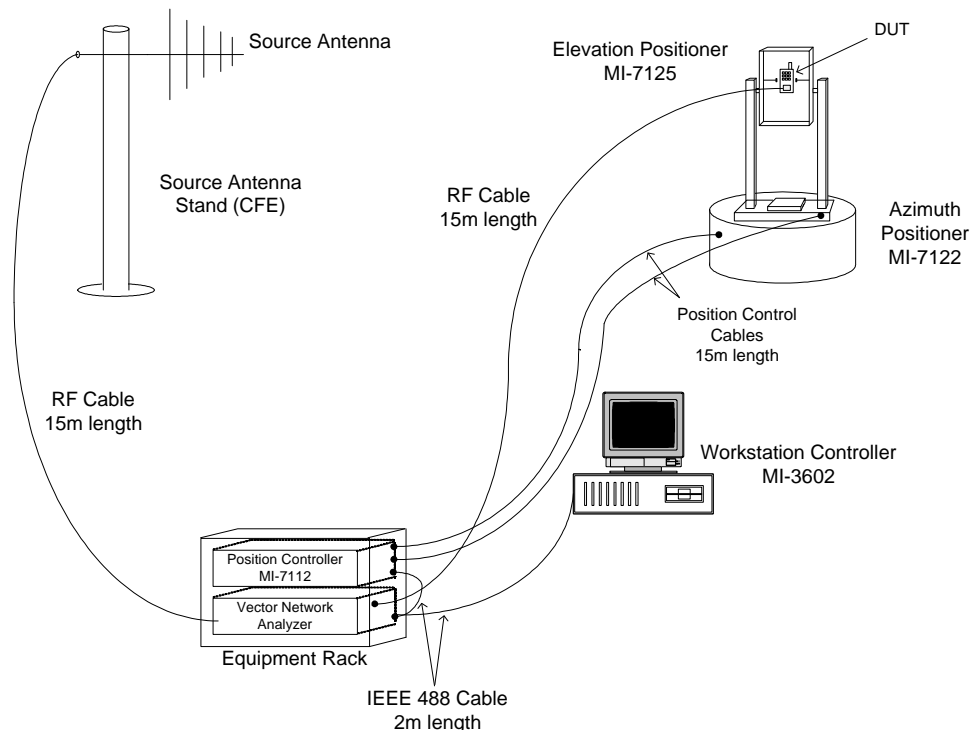

MI-3625 Specifications:

System Workstation:

- MI-3602 software and computer with monitor, keyboard, mouse, color printer, ethernet card, IEEE card
- Antenna measurement, analysis, and plotting software:
 - ▲ Automatic calculation of beam width, beam peak, location and depth of nulls, location and level of side-lobes, and gain
 - ▲ Polar or rectangular format plots

Receiver and Signal Source:

- Network Analyzer
- Dynamic range: 100 dB
- Input impedance: 50 ohms

Positioner:

- | | |
|--|--|
| <ul style="list-style-type: none"> ➤ MI-7122 Azimuth Positioner <ul style="list-style-type: none"> ▲ Diameter: 0.8 meter (31.5 inches) ▲ Vertical load handling: 75 kg (165 lbs) ▲ Speed: 0.3 to 3 rpm ▲ Rotation: ± 200 degrees ▲ Angular accuracy: 0.5 degrees | <ul style="list-style-type: none"> ➤ MI-7125 Elevation Positioner <ul style="list-style-type: none"> ▲ Total height: 1.8 meters (71 inches) ▲ Max. load: 10 kg (22 lbs) ▲ Material: PVC, weatherproof ▲ Positioning accuracy: ± 1 degree ▲ Rotation angle: 360 degrees |
|--|--|

Position Controller:

- MI-7112 provides up to four axes of control
- IEEE 488 based

Source Antenna:

- Linearly polarized, log periodic

Cables:

- Cables are provided to support equipment separation up to 15 meters.

Options:

- Standard gain antennas are available.
- Contact factory for alternate configurations.

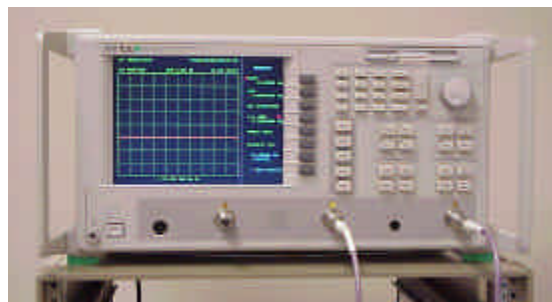

Vector Network Analyzer