

Series 31 Orthomode Feeds

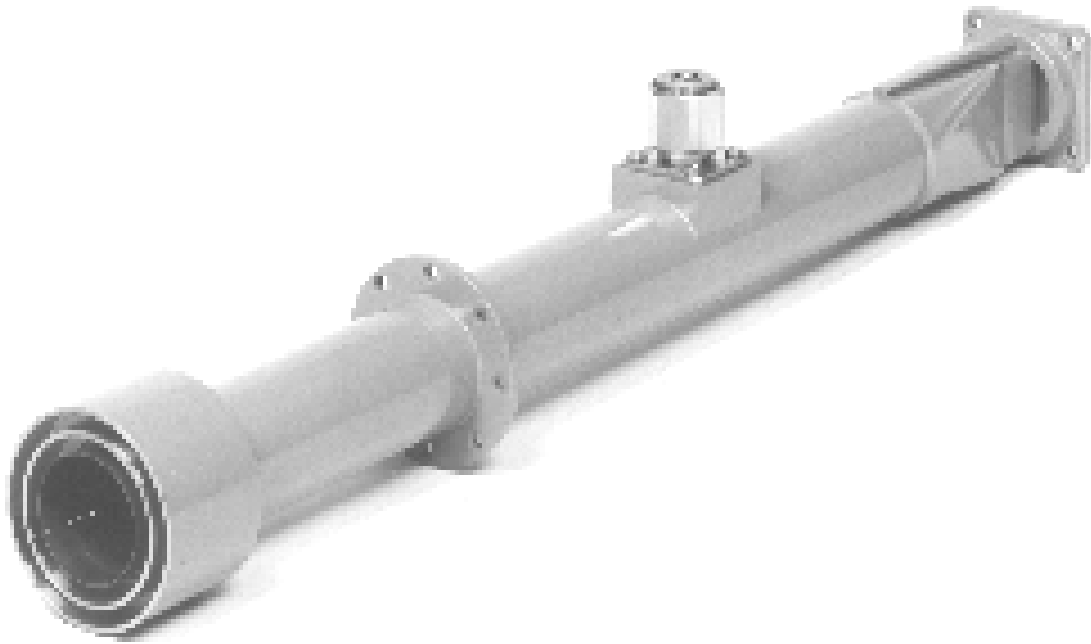

15731

Features

- High precision feeds offering two channel versatility
- Ideal for near-field probes and compact range feeds

Description

The MI Technologies Series 31 Orthomode Feeds are broadband dual-ported, dual-polarized feeds for antenna measurement applications. Five models are available, each operating over a standard rectangular waveguide band, to cover the 2.6 to 18 GHz frequency range.

The Series 31 feeds can be used as source antennas on antenna ranges, probes for near-field testing, feeds for MI Technologies' compact range, or in any application where a broadband orthomode feed is required.

The Series 31 feeds are broadband orthomode transducers implemented in circular waveguide feeding round waveguide apertures. The two ports of a Series 31 feed excite two orthogonal TE_{11} modes in the circular guide which radiate orthogonal linearly polarized fields with axial ratios greater than 35 dB.

The two orthogonal TE_{11} modes are excited by a rectangular-to-round waveguide transition and by an orthogonal coax-to-fineline transition which tapers to air-filled circular waveguide. The aperture is provided with a choke which reduces the back radiation from the feed.

Five feeds are available to cover the frequency band from 2.6 to 18 GHz:

Model 31-2.6	(S-band)	2.6 - 3.95 GHz
Model 31-3.9	(C-band)	3.95 - 5.85 GHz
Model 31-5.8	(XN-band)	5.85 - 8.2 GHz
Model 31-8.2	(X-band)	8.2 - 12.4 GHz
Model 31-12.4	(Ku-band)	12.4 - 18 GHz

Products - Antennas and Components

Series 31 Orthomode Feeds - continued

Each feed is available with a Type-N connector (standard) or an APC-7 connector (optional) on the integral coax-to-finline adapter.

The Series 31 feeds are provided with integral mounting flanges. These flanges permit the feeds to be mounted without pressure on the feed body which could deform the feed. This mounting arrangement helps to ensure the high-axial ratio of the Series 31 feeds.

The Series 31 feeds are designed to be used as dual-polarized probes for near-field measurements. The feeds can also be used as dual-polarized feeds for MI Technologies' Compact Range.

Spherical near-field testing requires the acquisition of large amounts of data on a sphere surrounding the test antenna at a small range length. Usually two orthogonal linearly polarized components of the E-field are measured. With a single-ported probe, which responds to a single linearly polarized component of the E-field, two lengthy raster scans are required to measure all the near-field data necessary to compute the far-field of a test antenna. The Series 31 feeds, which respond to two orthogonal linearly polarized components of the E-field, can be used to measure all the necessary data in a single raster scan. The Series 31 feeds can thus be used to reduce the data acquisition time required for spherical near-field testing.

A diagram showing the application of a Series 31 feed to a spherical near-field test is located below.

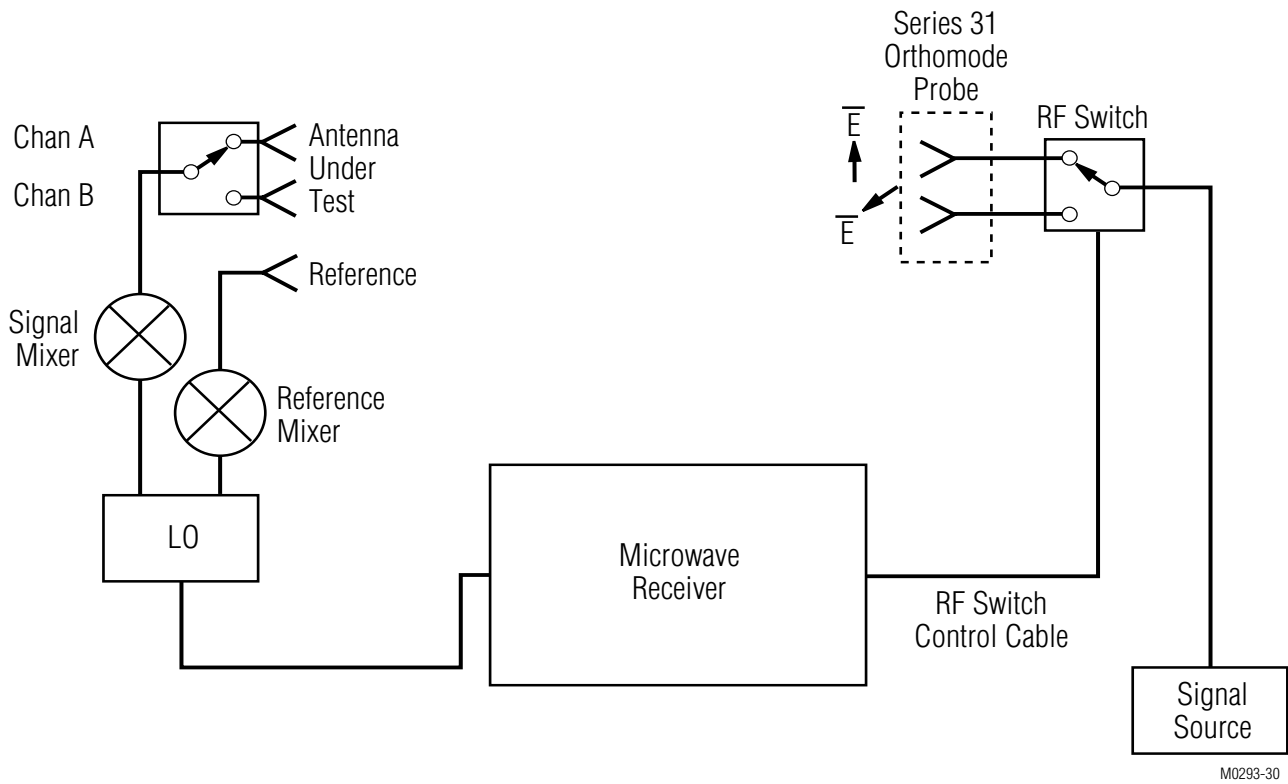

Application of a Series 31 Feed to a Near-Field Measurement

Products - Antennas and Components

Series 31 Orthomode Feeds - continued

Specifications

Frequency Range:

Model 31-2.6	2.6 - 3.95 GHz	S-Band
Model 31-3.9	3.95 - 5.85 GHz	C-Band
Model 31-5.8	5.85 - 8.2 GHz	XN-Band
Model 31-8.2	8.2 - 12.4 GHz	X-Band
Model 31-12.4	12.40 - 18 GHz	Ku-Band

VSWR (Maximum)

2.0:1

Axial Ratio (Minimum)

35 dB

Inter-Channel Isolation (Port-to-Port)

40 dB

Operating Temperature Range

10°C - 35°C

Output Configuration - Port #2

Standard - Precision Type-N coaxial connector (Model 31-xx)
Optional - APC-7 connector (Model 31A-xx)

Output Configuration - Port #1

Rectangular waveguide

Gain (Nominal at Band Edges)

7 - 10 dB

Beamwidth

50 degrees nominal

Maximum Power

20 Watts (Average)

Weight

31-2.6	19 lbs (8.6 kg)
31-3.9	12 lbs (5.5 kg)
31-5.8	9 lbs (4.1 kg)
31-8.2	2 lbs (6.9 kg)
31-12.4	1 lbs (0.5 kg)

Ordering Information

When ordering a Series 31 feed with an APC-7 connector on the second port, use the format of "31A-xx." Otherwise, use "31-xx."

Optional hardware may be added to a Series 31 feed which supports mounting the feed into a MI Technologies compact range feed positioner. When ordering, add an "M" to the end of the model number to designate the addition of the compact range mounting hardware. For example, "31-3.9M" is used to order the Model 31-3.9 feed with a type-N coaxial connector on the second port and compact range mounting hardware.

Options

Not Applicable

Accessories

Not Applicable

Products - Antennas and Components

Series 31 Orthomode Feeds - continued

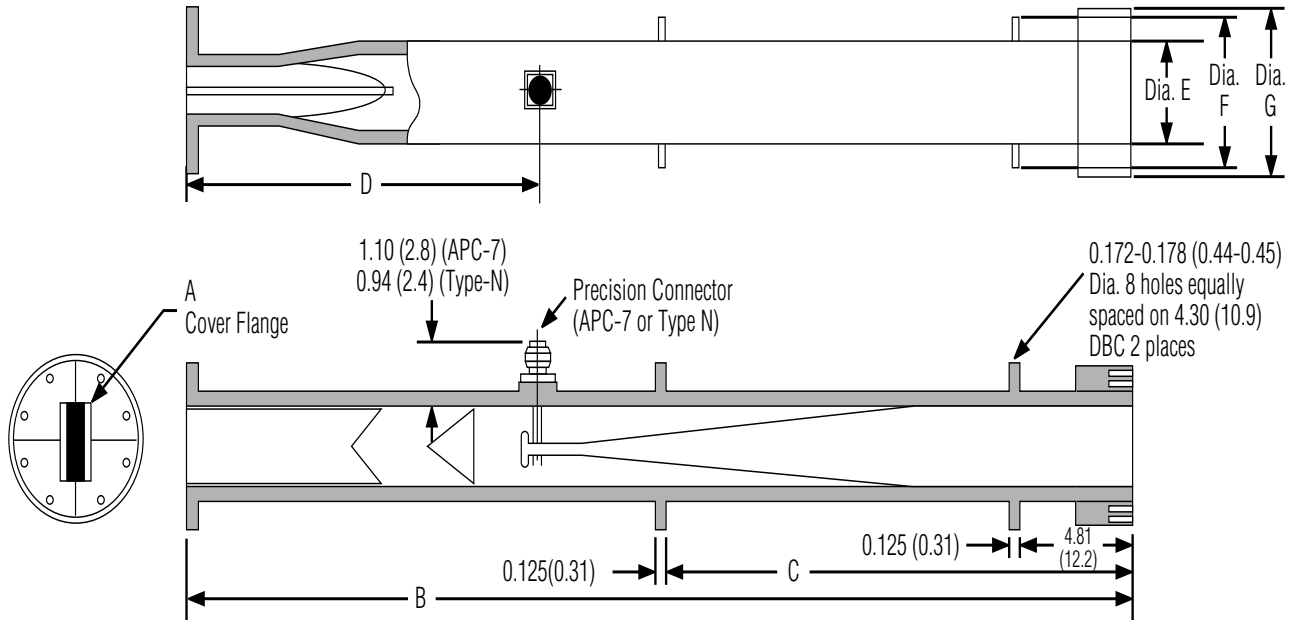

Model 31-	A	B	C	D	E	F	G
2.6	UG 584/U	45.10 (114.6)	22.50 (57.2)	17.00 (43.2)	3.80 (9.7)	5.82 (14.8)	6.00 (15.2)
3.9	UG 407/U	32.05 (81.4)	16.00 (40.6)	13.13 (33.4)	2.64 (6.7)	4.20 (10.7)	4.40 (11.2)
5.8	UG 441/U	20.00 (50.8)	10.00 (25.4)	8.40 (21.3)	1.90 (4.8)	3.00 (7.6)	2.90 (7.4)

M0293-29

All dimensions in inches (cm).

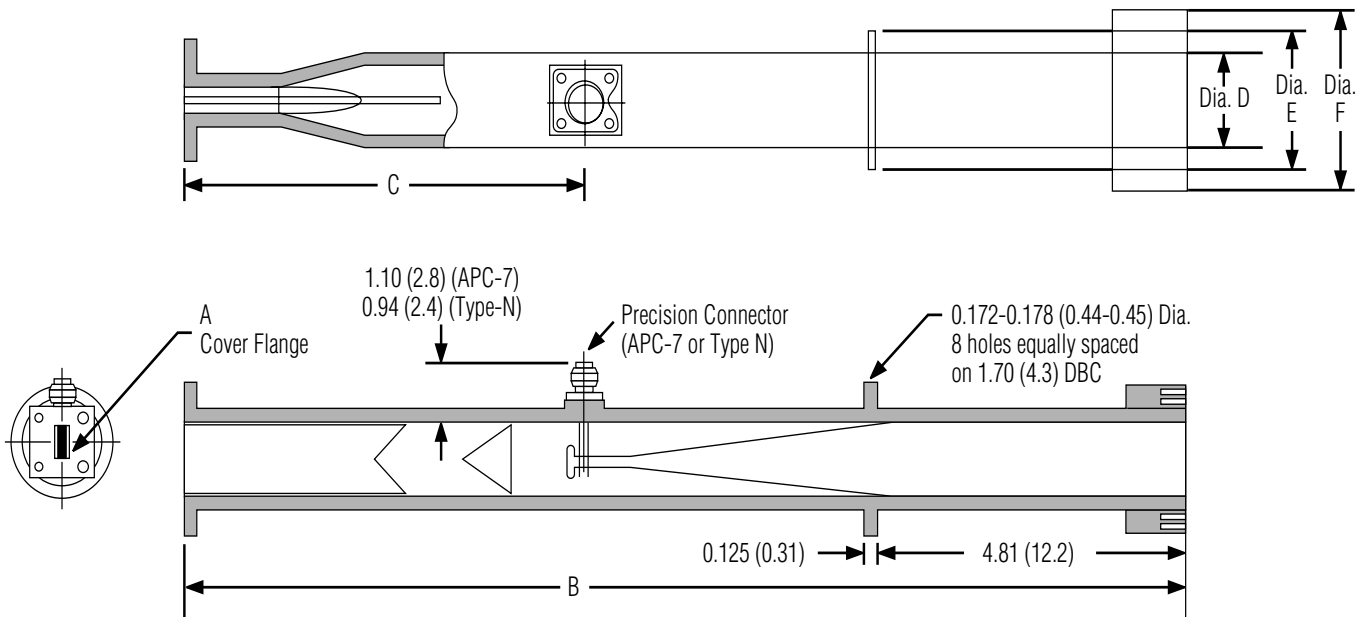

Model 31-	A	B	C	D	E	F
8.2	UG 39/U	15.70 (39.9)	6.70 (17.0)	1.25 (3.2)	2.00 (5.1)	1.95 (5.0)
12.4	UB 419/U	13.42 (34.1)	4.57 (11.6)	0.88 (2.2)	2.00 (5.1)	1.50 (3.8)

M0293-28